

个人名片粘贴处

TOYURIS



TOYURIS

江苏同轭智能科技有限公司

Jiangsu Tongyun Intelligent Technology Co., LTD

江苏省丹阳市精密制造产业园  
Precision Manufacturing Industrial Park  
Danyang City, Jiangsu Province  
www.toyuris.com www.jstoyuris.com

江苏同轭智能科技有限公司

Jiangsu Tongyun Intelligent Technology Co., LTD

帮助钣金工厂，低风险实现先进智能制造

Assist sheet metal fabrication plants in achieving advanced intelligent manufacturing with minimal risk.



# ABOUT US

**江苏同韞智能科技有限公司**是一家专注于钣金自动化智能装备和钣金生产智能管理软件的研发、生产、销售及服务的智能装备企业，公司位于江苏省镇江，国内在华北、华东、华南、西北、西南，在东南亚、欧洲、北美均有分支办事机构。

Jiangsu Tongyun Intelligent Technology Co., Ltd. is an intelligent equipment enterprise specializing in the R&D, manufacturing, sales, and service of sheet metal automation equipment and intelligent production management software. The company is located in zhenjiang, Jiangsu Province. In China, Tongyun has branch offices in North China, East China, South China, Northwest China, and Southwest China, and it also operates in Southeast Asia, Europe, and North America.

## 我们的服务 Our Services

同韞将抱着合作共赢心态与您共同发展，针对您的不同的工艺及订单情况，我们技术团队将紧密与您进行沟通，保障您的智工厂规划顺利、落地顺利、使用顺利。

Tongyun adheres to a win-win cooperation philosophy. Based on your specific processes and order requirements, our technical team will maintain close communication with you to ensure smooth planning, implementation, and operation of your smart factory.



### 现场沟通分析

与您进行现场沟通、了解您的现场情况，沟通初步的使用需求、工艺路线、优化方案等

#### On-Site Communication & Analysis

We conduct on-site visits to understand your current production conditions, discuss initial usage requirements, process routes, and optimization solutions.



### 确定规划方案

根据您的现场实际情况我们技术与工艺团队将出具适合您现场的技术方案并与您详细沟通

#### Solution Planning

According to your actual site conditions, our technical and process teams will develop a tailored technical proposal and communicate the details with you thoroughly, process routes, and optimization solutions.

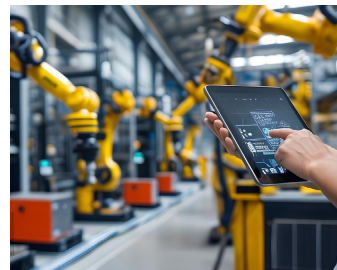

### 项目实施

我们将安排一对一项目经理进行项目负责，工艺团队实时与您沟通，专业的技术人员为您培训

#### Project Implementation

A dedicated project manager will be assigned for one-on-one coordination. Our process team will maintain real-time communication, and professional technicians will provide training support.

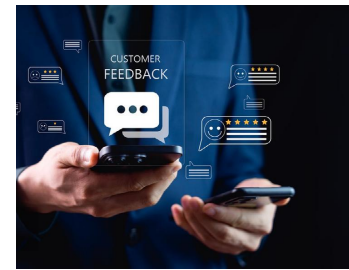

### 售后服务

我们将指定售后服务人员为您提供7\*24小时服务，保障设备正常运行，并定期进行回访及检修。

#### After-Sales Service

We assign dedicated after-sales service personnel to provide 7\*24-hour technical support, ensure stable equipment operation, and conduct regular follow-ups and maintenance inspections.



公司集结机械、软件、电气技术团队，凭硬核研发实力与自主知识产权。赋能全球客户落地自动化与智能化工厂，与国内外多家主机厂缔结战略伙伴，合力推动制造环节的持续优化与价值提升。

The company brings together professional teams in mechanical engineering, software development, and electrical control. With strong R&D capabilities and independent intellectual property rights, Tongyun empowers global customers to implement automated and intelligent factories. It has established strategic partnerships with leading machine manufacturers worldwide, jointly promoting continuous optimization and value enhancement in manufacturing processes.



# 客户群体 Customer

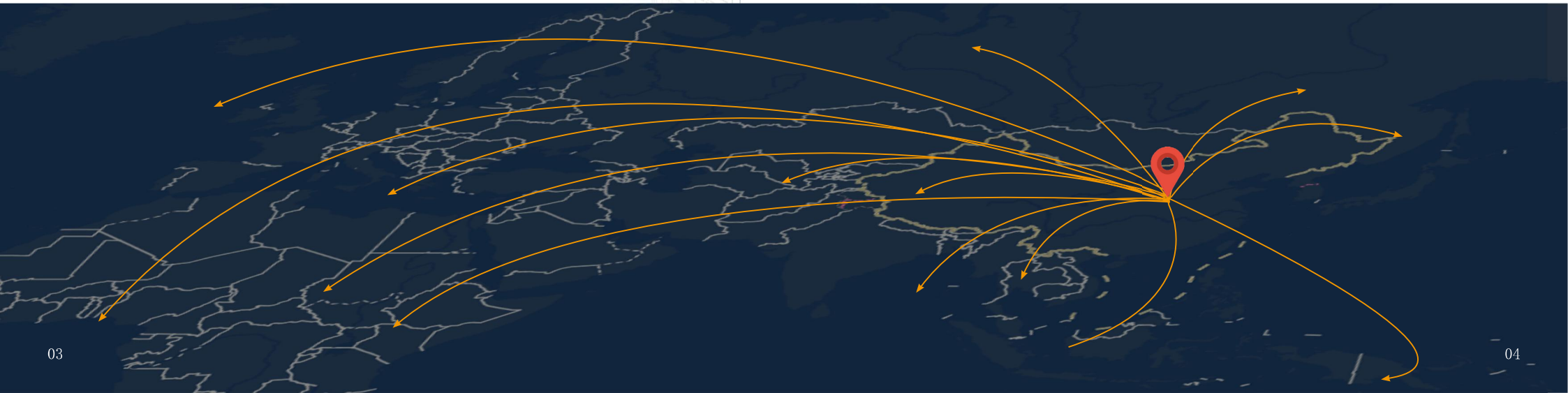

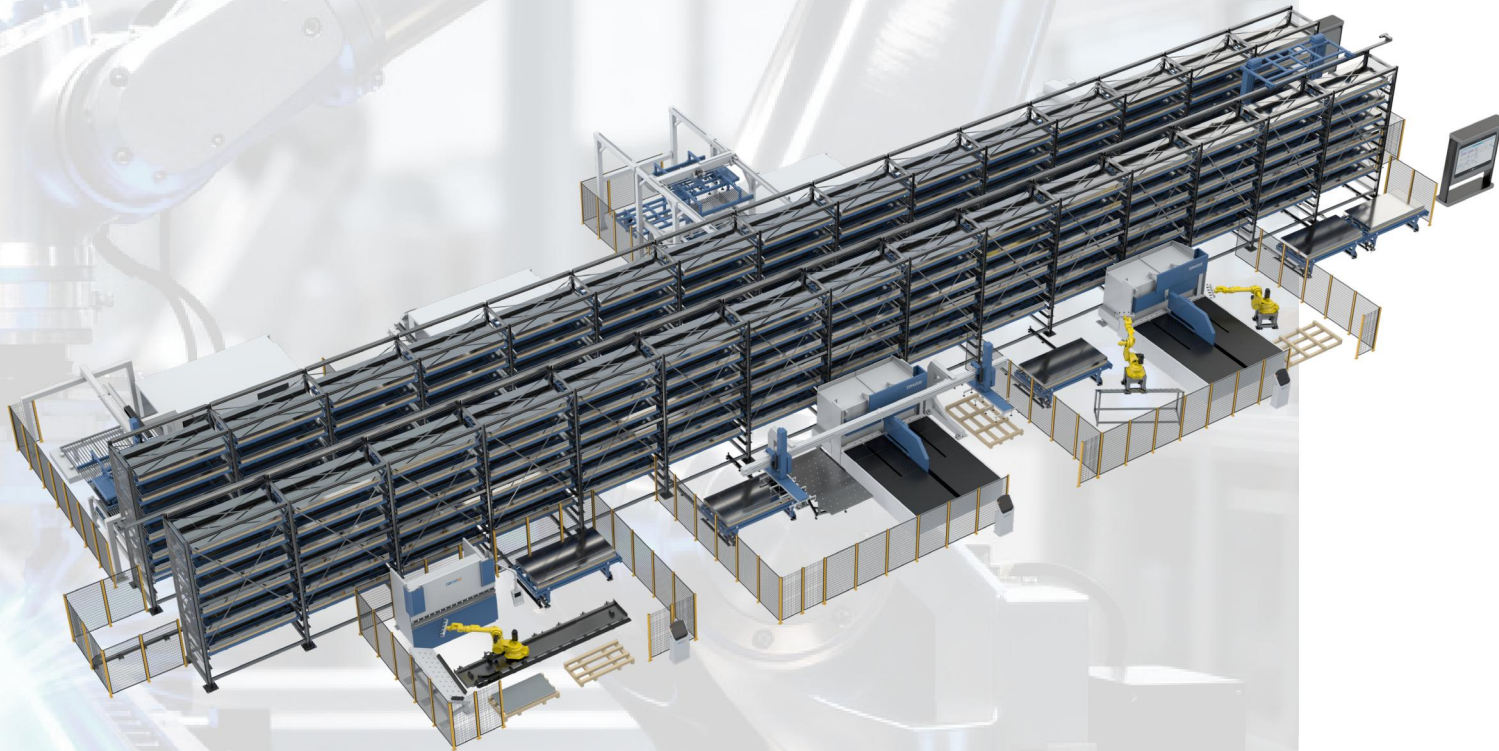
**设备组成:****System Composition:**

- 1 控制管理软件  
Control & Management Software
- 2 物流仓储中心  
Logistics & Storage Center
- 3 数控冲床自动化  
CNC Punch Automation
- 4 激光切割机自动化  
Laser Cutting Automation
- 5 激光上下料 + 分拣自动化  
Laser Loading/Unloading + Sorting Automation
- 6 折弯机自动化  
Press Brake Automation
- 7 折弯中心自动化  
Panel Bender Automation
- 8 数字化分拣工作站  
Digital sorting workstation.

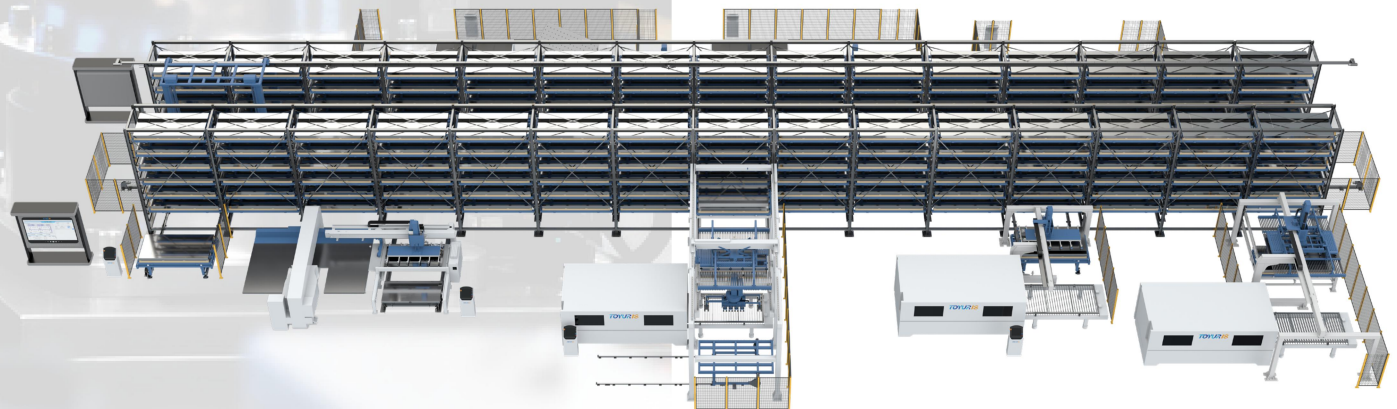

### 1、控制管理软件 Control & Management Software

TY-WIS 是一款钣金数字化生产线智能管理软件。作为生产线的“大脑”和“神经中枢”，它聚焦于钣金智能生产中的全品类物料管理与全流程数字化运营，通过与自动化设备的深度结合，实现钣金智能生产线的自动化、信息化管理，进而驱动柔性生产单元进行自动化生产与作业协同。

TY-WIS is an intelligent digital management platform for sheet metal production lines. Acting as the brain and central control hub of the entire line, it enables end-to-end material traceability and full-process digital operation. By deeply integrating with automation equipment, TY-WIS empowers intelligent sheet metal production lines with seamless automation, real-time data management, and coordinated operation of flexible manufacturing units.

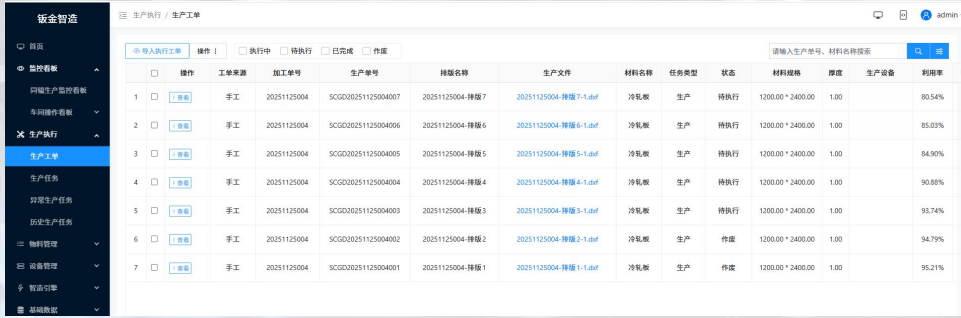

核心订单管理模块，加载 AI 大模型，管理生产订单，智能排程。支持工单多源导入、任务实时监控、优先级动态调整及柔性控制。

The core order management module integrates AI large language models to manage production orders and enable intelligent scheduling. It supports multi-source work order import, real-time task monitoring, dynamic priority adjustment, and flexible production control.

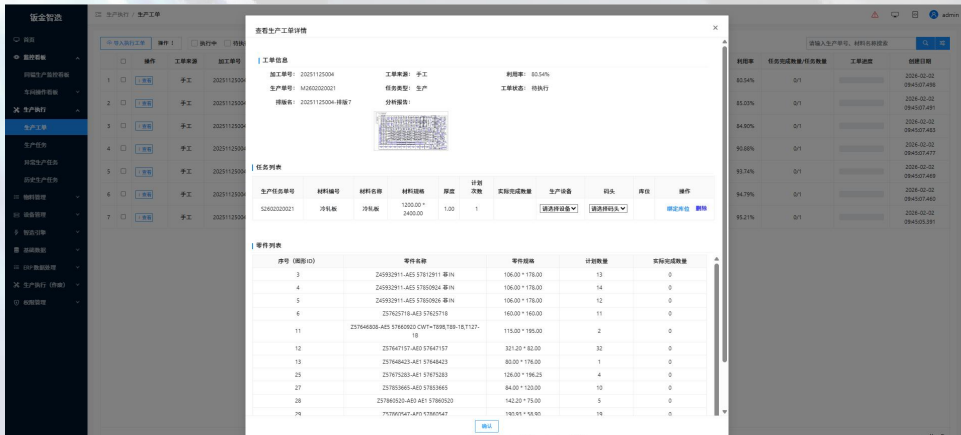

工单管理模块，支持工单详情查看，零件信息查看等。

Work Order Management Module enables detailed work order tracking, part information viewing, and related production data access.

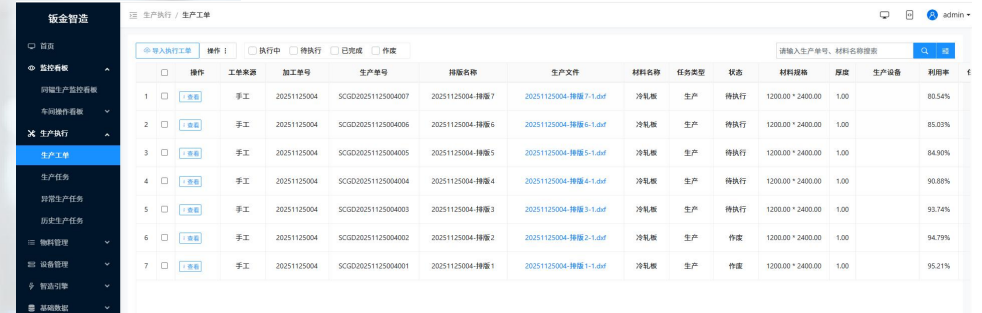

全面管理接入的设备，包括设备门户、分组、新增与配置、数据流程监控、报警监控及实时/历史数据图表展示。支持多种工业协议接入。

Comprehensive equipment management, Centralized management of connected equipment, including device portal, grouping, addition and configuration, data flow monitoring, alarm monitoring, and real-time/historical data visualization. Supports integration with multiple industrial communication protocols.



多维度看板：提供首页全局概览、设备报警看板、生产任务看板、钣金加工实时看板等。

Multi-Dimensional dashboards. Provides a global overview homepage, equipment alarm dashboard, production task dashboard, and real-time sheet metal processing dashboard.

## 2、仓储中心介绍 Storage &amp; Logistics Center

## 料库介绍 Intelligent Storage System

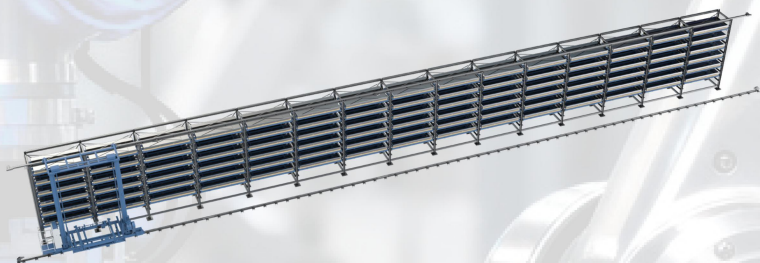

高密度智能存储：集中存储原材料、加工后的半成品及分拣好的零件成品。

结构形式：焊接牛腿式货架，采用库架分离式结构。

High-density centralized storage for raw materials, semi-finished, and finished parts  
Welded cantilever rack structure with separated rack-frame design

## 堆垛机介绍 Stacker Crane

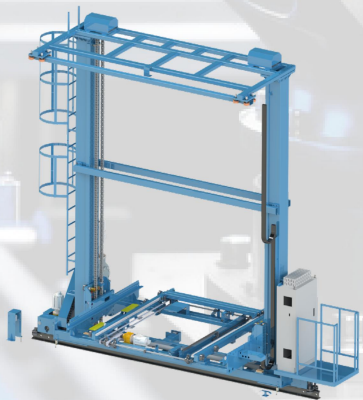

功能：在巷道内进行 X（水平行走）、Y（垂直提升）、Z（取料）三轴运动，完成指定库位托盘的自动存取。

Performs X (horizontal), Y (vertical), and Z (fork retrieval) three-axis movement for automatic pallet storage and retrieval.

## 液压台车 Hydraulic cart

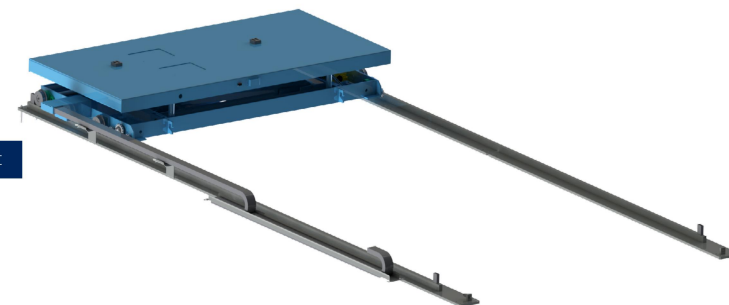

液压台车集成了电机行走、液压升降、智能高度检测与物流通讯接口的智能设备。无缝衔接了立体库、加工设备，是构建柔性化、无人化产线物流的关键基础设施。

The hydraulic transfer cart is an intelligent device integrating motorized travel, hydraulic lifting, intelligent height detection, and logistics communication interfaces.

It seamlessly connects the automated storage system with processing equipment, serving as a key infrastructure component for building flexible and unmanned production-line logistics.

## 平移台车 Inbound &amp; Outbound Transfer Cart

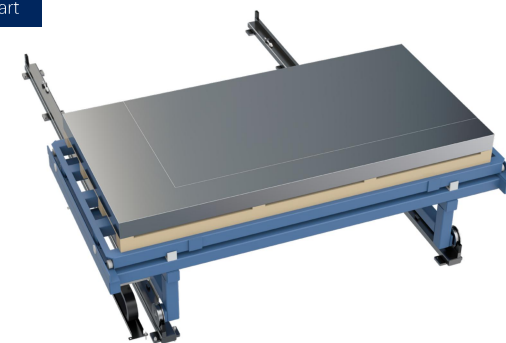

平移台车是自动化立体仓库物料进出料库的传送与交接核心设备，主要负责在库内巷道口与外部区域之间转运托盘物料。

The shuttle transfer cart is the core conveying and transfer equipment for material inbound and outbound operations in an automated storage system.

## 3、数控冲床上下料 CNC Punch Automation

EP3015-01

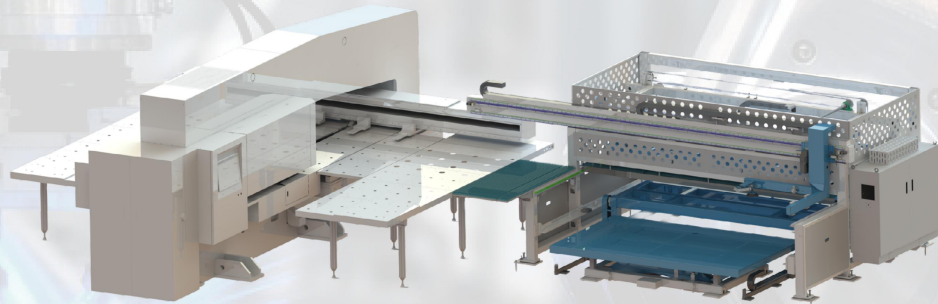

是一款功能完整、性能可靠、聚焦于 3015 规格板材的单边式数控冲床自动上下料解决方案，是提升钣金冲压环节自动化水平和生产效率的关键设备。采用单轴进行上下料，机构更紧凑。

CNC Punch Automation is a comprehensive and reliable single-side automatic loading and unloading system tailored for 3015 sheet metal CNC punching machines. It significantly improves automation efficiency in sheet metal stamping operations. Featuring a single-axis handling mechanism, the system offers a more compact and space-efficient structure.

EP3015-02

是一款设计成熟、部件可靠、致力于实现数控冲床“关灯生产”的标准化单边自动上下料单元，是提升钣金冲压环节自动化水平的核心装备。采用双轴同步结构，相应速度更快。

A mature and reliable single-side automatic loading/unloading unit designed for "lights-out" punch production. Features dual-axis synchronous structure for faster response.

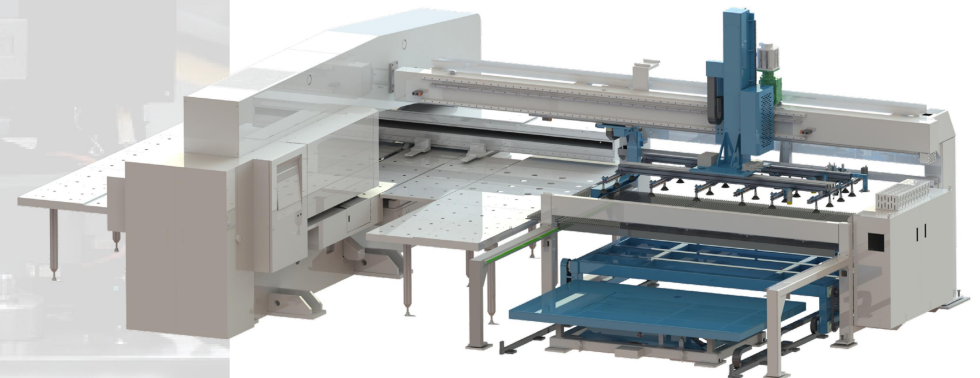

## 4、激光切割机上下料 Laser Loading &amp; Unloading Automation

## 激光切割机上下料 Laser Loading &amp; Unloading Automation

激光上下料方案是一种布局紧凑、柔性高、效率高且易于信息化集成的自动化解决方案。它通过长行程的横向移动或竖向移动实现多点作业与物流协同，是实现钣金柔性自动化生产线、特别是多激光设备协同生产的理想选择。结合现场场地，工艺流程可以设置不同布局，实现空间更好利用。

Laser Loading & Unloading Automation is a compact, highly flexible, and high-efficiency automation solution that is easy to integrate with digital management systems. Through long-stroke horizontal or vertical movement, it enables multi-point operation and coordinated material flow. It is an ideal solution for flexible sheet metal automation lines, especially for collaborative production involving multiple laser cutting machines.

Based on on-site space conditions, the process flow can be configured with different layout options to achieve optimal space utilization.

## 5、激光上下料 + 分拣 Laser Loading + Sorting Automation

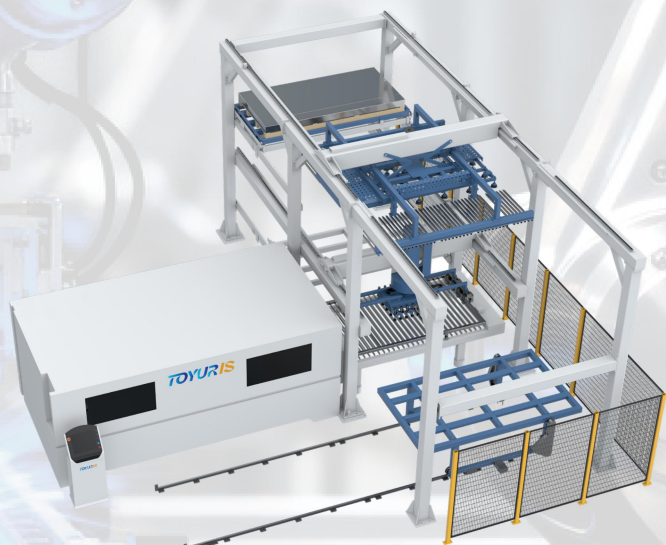

## 激光上下料 + 分拣 Laser Loading + Sorting Automation

这是一个集“激光切割机自动上下料”与“半成品自动分拣”于一体的复合自动化模块。它是钣金柔性生产线中连接激光切割与后续工序（如人工分拣、折弯、入库）的关键节点，旨在实现“自动取料、自动上料、激光加工、自动分拣、自动下料/转运”的连续生产闭环。

This is an integrated automation module combining automatic loading/unloading for laser cutting machines and automatic semi-finished part sorting.

It serves as a key connection point in a flexible sheet metal production line, linking laser cutting with downstream processes such as manual sorting, bending, and warehousing. The system is designed to achieve a continuous production loop of automatic material picking, automatic loading, laser processing, automatic sorting, and automatic unloading/transfer.

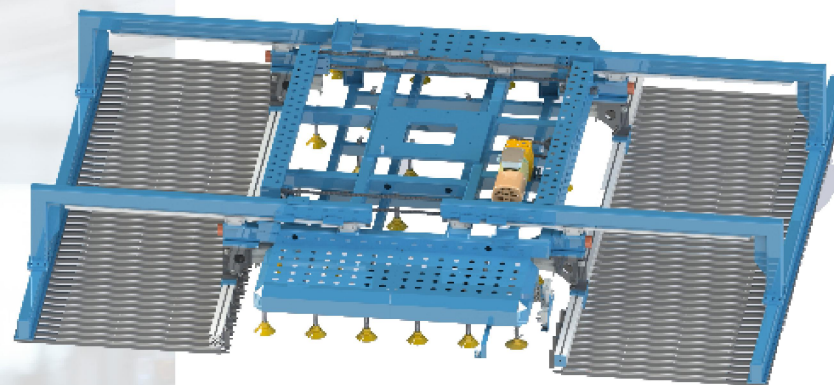

## 吸盘抱叉机构 V suction-cup and fork handling

是激光切割机自动上下料单元的核心执行部件。它是一个复合式（一体式）工装，在一个结构框架上集成了真空吸盘上料装置和抱叉（插齿）下料装置。

V suction-cup and fork handling is the core actuating unit of the automatic loading and unloading system for laser cutting machines. It is a composite (integrated) tooling assembly that combines a vacuum suction loading device and a fork-type (toothed insertion) unloading device within a single structural frame.

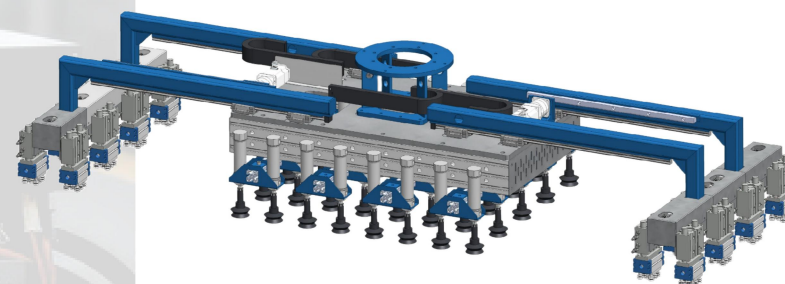

## 激光分拣 Laser Sorting Module

激光分拣抓手并非一个独立设备，而是集成在激光上下料复合机械手（桁架）上的一个功能模块或组件。其主要功能是：在激光切割完成后，根据激光切割机的排版信息进行自动生成分拣任务，根据分拣任务调整抓手的长度区域、吸盘区域、旋转角度等实现半成品的自动分拣。

The laser sorting gripper is not an independent piece of equipment, but a functional module integrated into the laser loading and unloading composite manipulator (gantry system).

Its primary function is to automatically generate sorting tasks based on the nesting data from the laser cutting machine after cutting is completed. According to the generated sorting tasks, the gripper adjusts its length range, suction cup area, and rotation angle to achieve automatic sorting of semi-finished parts.

## 6、折弯机械手 Press Brake Robot Automation

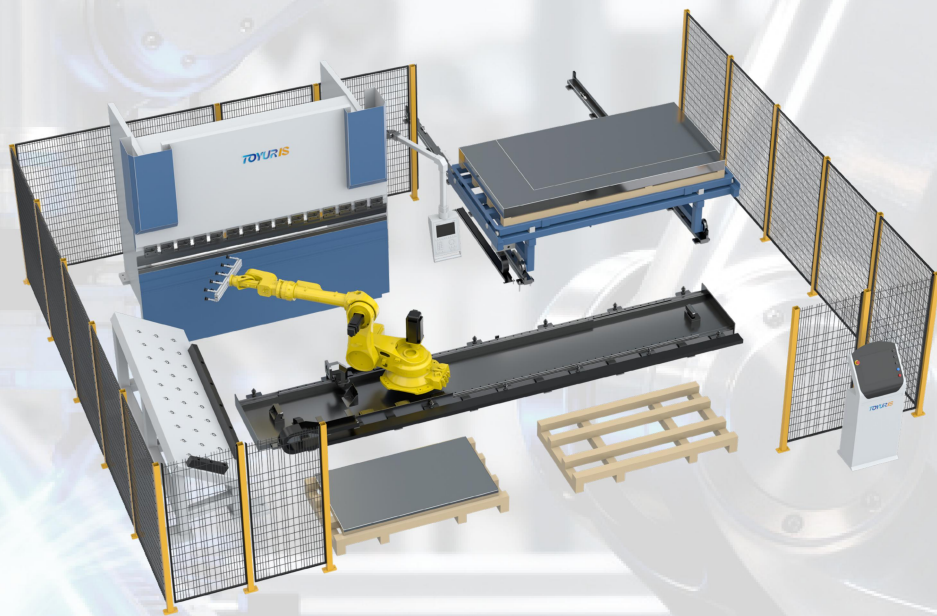

折弯机械手 Press Brake Robot Automation

折弯机械手自动化单元是钣金柔性生产线（智能制造系统）中实现折弯工序无人化、自动化的核心部分。

其主要目的为：替代人工，实现板料从料库 / 上料区到折弯机折弯、翻面、再到成品码垛的全流程自动化作业，旨在提升效率、保障一致性、实现黑灯生产。

The press brake robotic automation unit is a core component of a flexible sheet metal production line (intelligent manufacturing system), enabling unmanned and automated bending operations.

Its primary objective is to replace manual labor by realizing fully automated processing of sheet materials—from the material storage or loading area to bending on the press brake, part flipping, and final finished-product stacking. The system is designed to enhance production efficiency, ensure process consistency, and support lights-out manufacturing.

## 7、折弯中心上下料 Panel Bender Automation

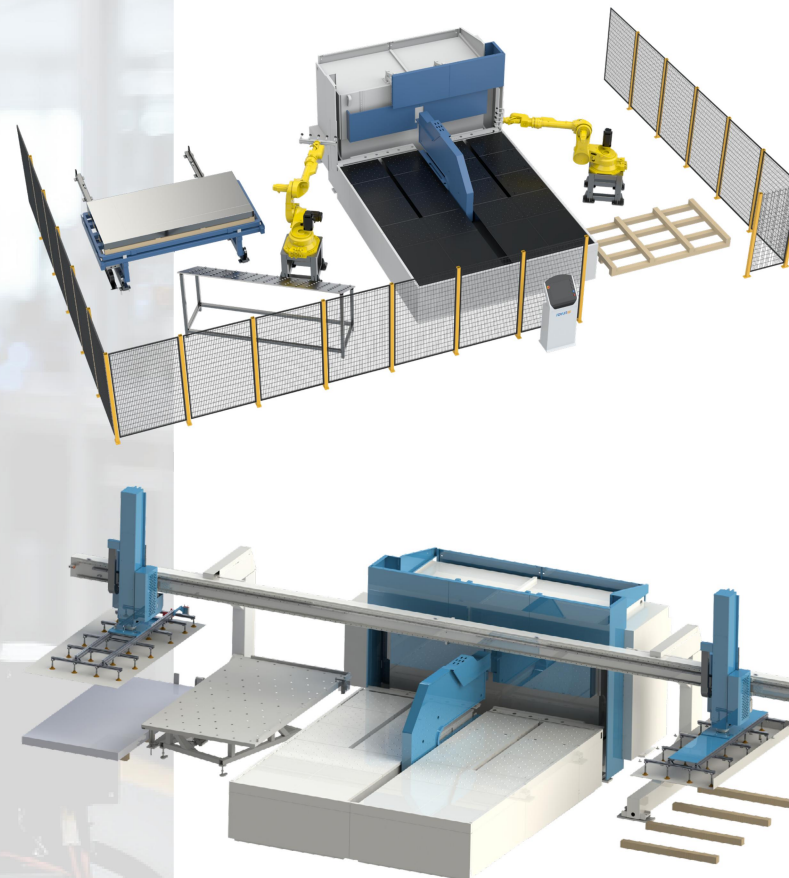

折弯中心上下料 Panel Bender Automation

由折弯中心与工业机器人 / 行架机械手及全套周边辅助设备组成的自动化单元，旨在替代人工，实现从取料、定位、送料到下料码垛的全流程自动化。

Panel Bender Automation is an automated unit composed of a press brake center, an industrial robot or gantry manipulator, and a complete set of peripheral auxiliary equipment. It is designed to replace manual labor and realize full-process automation, from material picking, positioning, and feeding to unloading and palletizing.

### 8、数字化分拣工作站 Digital sorting workstation.

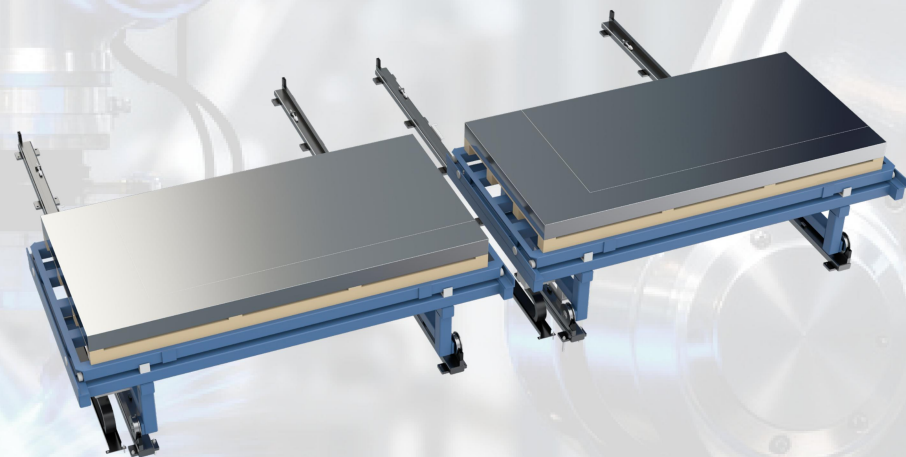

#### 数字化分拣工作站 Digital sorting workstation.

数字化分拣工作站是当前钣金智能制造中连接全自动化切割与后续工序（如折弯）或智能仓储的一个必要且高效的人机协作节点。它通过自动化设备承担重载搬运，将人力集中在需要灵活判断和精细操作的分拣工作上，是智能产线实现柔性生产的关键环节。

The digital sorting workstation serves as an essential and highly efficient human-machine collaboration node in modern sheet metal intelligent manufacturing. It connects fully automated cutting processes with subsequent operations (such as bending) or intelligent warehousing.

By allowing automated equipment to handle heavy material transfer tasks, human operators can focus on sorting activities that require flexible judgment and precise handling. As a result, it becomes a critical component in enabling flexible production within intelligent manufacturing lines.

#### 分拣报工看板 Sorting Reporting Dashboard

出库人工分拣时由中控软件统一调度，并通过扫码枪、看板、PDA 等硬件实现高效的人机交互与数据图形展示，最终实现车间生产的透明化、可追溯化管理、针对式分拣。

During outbound manual sorting, operations are centrally coordinated by the main control software. Efficient human-machine interaction and visual data presentation are achieved through hardware devices such as barcode scanners, display boards, and PDAs. This ultimately enables transparent workshop operations, full traceability management, and targeted sorting.

**生产报工系统**

激光切割机1号-IGCG001

待生产任务: 2 | 今日完成任务: 0

待生产任务列表:

任务单号	创建时间	操作
S2602020022	2026-02-02 09:45:05.391	<a href="#">分拣单</a> <a href="#">完成任务</a>
S2602020023	2026-02-02 09:45:07.469	<a href="#">分拣单</a> <a href="#">完成任务</a>

共 0 条记录, 每页 10 条

**任务信息**

生产任务单号: S2602020022 | 材料任务号: 暂无数据 | 材料名称: 冷轧板

**零件列表**

序号(图形ID)	零件名称	零件规格	计划数量	实际完成数量
8	Z57641243-AE1 57641243,44 HKZ=14	128.00 * 146.00	6	0
9	Z57644874-AE4 57644874 GQs1160 LKR=760	1155.00 * 489.50	4	0
13	Z57648423-AE1 57648423	80.00 * 176.00	1	0
32	Z57863219-AE1 57863219@a216f HB=700	106.00 * 121.00	4	0

## 设备组成:

## System Composition:

- 1 塔库自动化  
Tower Storage Automation
- 2 出入库台车  
Inbound & Outbound Transfer Carts
- 3 激光上下料自动化  
Laser Loading Automation
- 4 激光分拣自动化  
Laser Sorting Automation
- 5 输送传输定位线  
Conveyor Positioning Line
- 6 折边机上下料自动化  
Edge Bending Automation

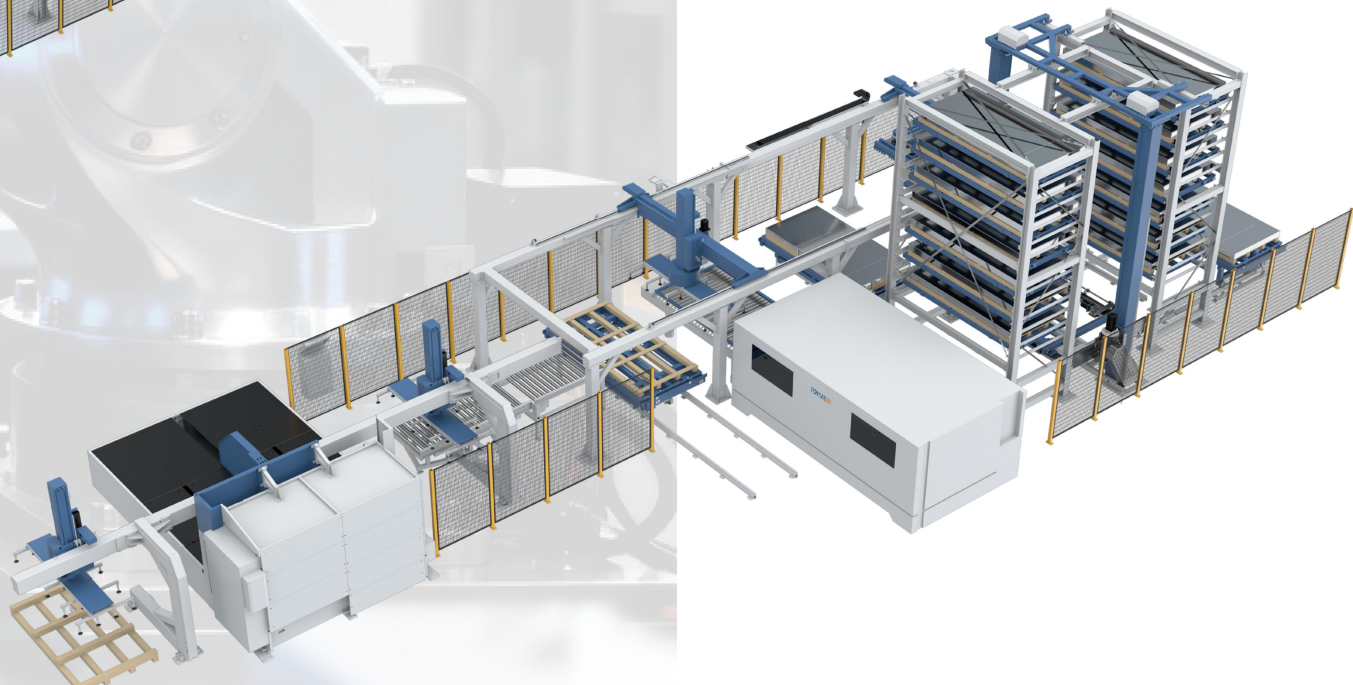
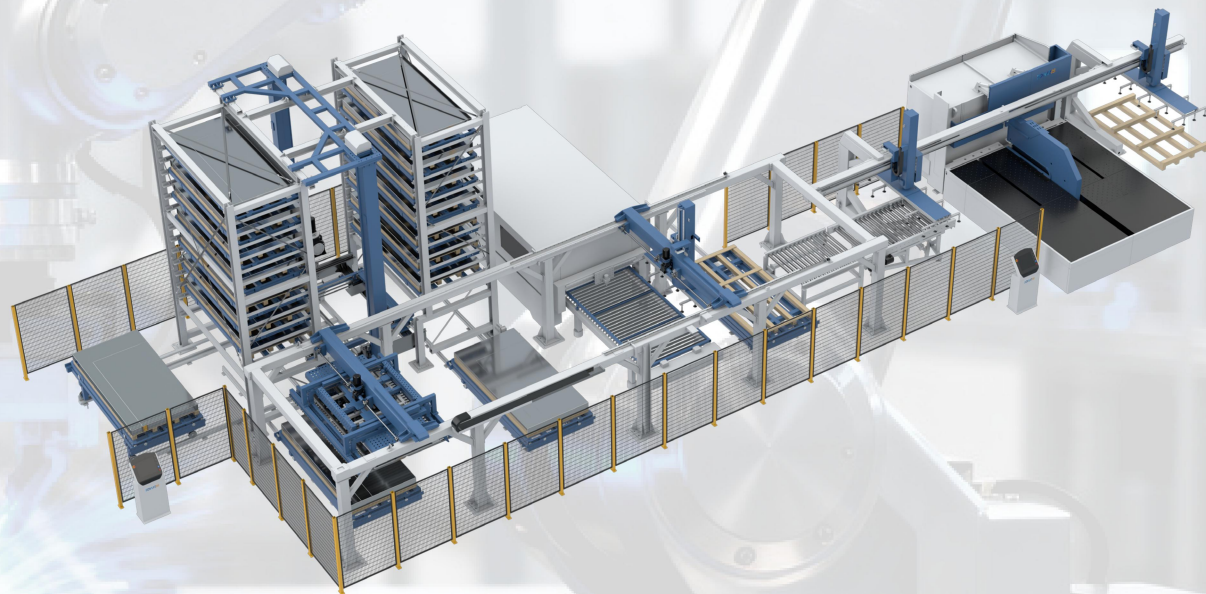

## 1、塔库 Tower Storage



## 双塔料库 Dual-Tower System

双塔料库适合生产计划复杂，有多种原材料需要频繁切换为多台不同类型设备供料。适合复杂、高产、求极致的柔性产线。

The dual-tower storage system is ideal for complex production planning scenarios where multiple types of raw materials must be frequently switched to supply different machines.

It is particularly suitable for complex, high-output, and highly flexible production lines that demand maximum efficiency and operational flexibility.



## 单塔料库 Single-Tower System

单塔库针对规模化生产，实现该工位的自动化供料与产能提升，适合单点突破或组建模块化、可扩展的产线。

The single-tower storage system is designed for large-scale production, enabling automated material supply and capacity improvement for specific workstations.

It is well-suited for single-process optimization or for building modular, scalable production lines.

## 2、出入库台车 Transfer Carts

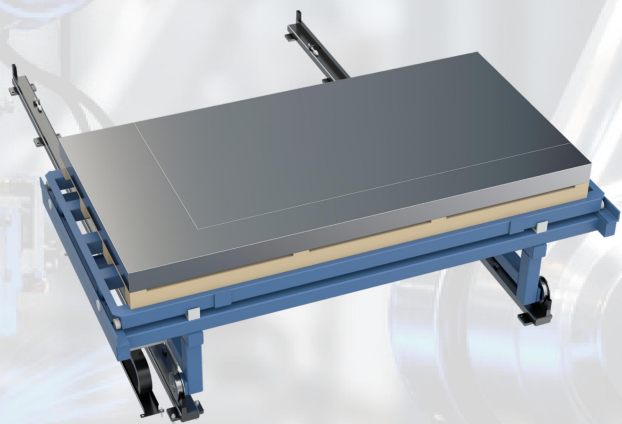

单层台车 A single-layer cart

单层台车承载一个托盘。广泛应用于原材料入库、设备上料、人工分拣区进出料。

A single-layer cart carries one pallet and is widely used for raw material inbound storage, machine loading, and material transfer to and from manual sorting areas.



原料小车 raw material cart

原料小车是自动化上料流程的核心执行单元和物料载体，载以木托盘为整垛的金属板材原材料，自动化转运，上料对接，自动化物流衔接。

The raw material cart serves as the core execution unit and material carrier in the automated loading process. It transports full stacks of metal sheets placed on wooden pallets, enabling automatic transfer, machine docking, and seamless logistics integration.

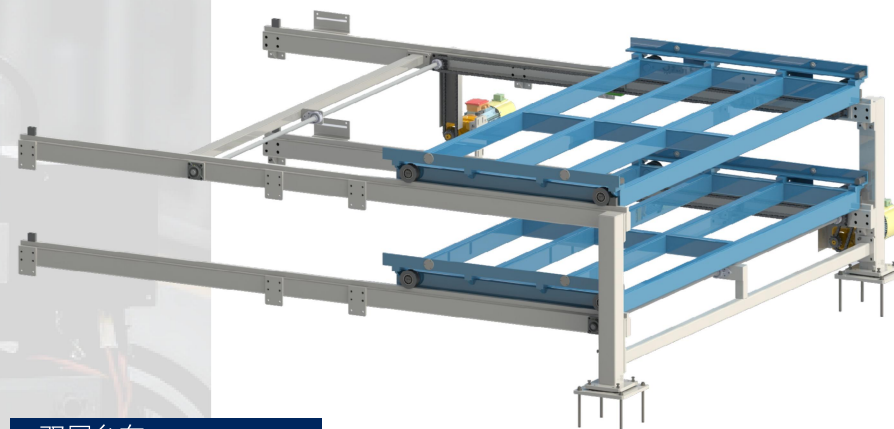

双层台车 double-layer cart

双层台车为两台激光进行服务，实现料库双层出料，两台激光进行不同板材加工。

台车为整体型材焊接，台车驱动方式为电机驱动，每一个台车配备一个电机，台车和上料吸盘对应。

The double-layer cart is designed to serve two laser machines simultaneously, enabling dual-level material output from the storage system and supporting different sheet processing tasks on each laser. The cart features an integral welded steel structure and is motor-driven. Each cart is equipped with an independent motor and precisely aligned with the loading suction system for accurate docking.

## 3、激光上下料 Laser Loading System

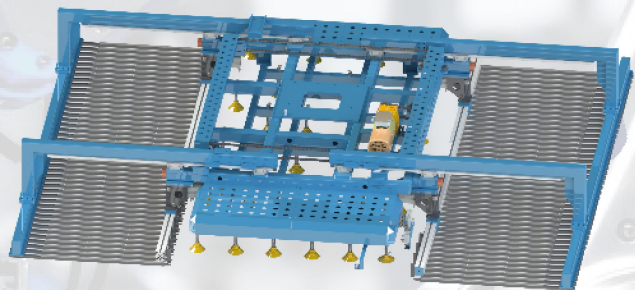

## 吸盘抱叉装置 Vacuum Suction &amp; Fork Integrated Device

是激光切割机自动上下料单元的核心执行部件。它是一个复合式（一体式）工装，在一个结构框架上集成了真空吸盘上料装置和抱叉（插齿）下料装置。

This device is the core execution component of the laser cutting machine's automatic loading and unloading unit. It is a composite (integrated) tooling system that combines a vacuum suction loading mechanism and a fork-type (insertion tooth) unloading mechanism within a single structural frame.

## 4、激光分拣 Laser Sorting

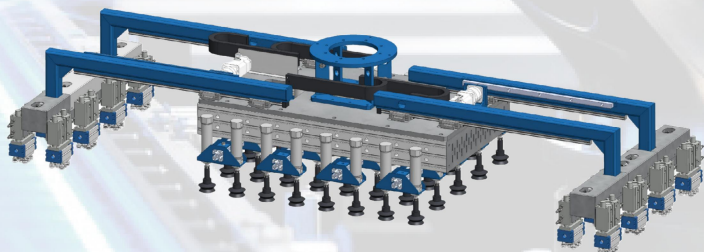

## 激光分拣抓手 Laser Sorting Gripper

激光分拣抓手并非一个独立设备，而是集成在激光上下料复合机械手（桁架）上的一个功能模块或组件。其主要功能是：在激光切割完成后，根据激光切割机的排版信息进行自动生成分拣任务，根据分拣任务调整抓手的长度区域、吸盘区域、旋转角度等实现半成品的自动分拣。

The laser sorting gripper is not an independent machine but a functional module integrated into the laser loading/unloading gantry manipulator. After laser cutting is completed, it automatically generates sorting tasks based on the nesting layout data from the laser cutting machine. According to the sorting tasks, it adjusts the gripping length range, suction cup area, rotation angle, and other parameters to achieve automatic sorting of semi-finished parts.

## 5、输送传输定位线 Conveyor &amp; Positioning Line



## 输送传输定位线 Conveyor &amp; Positioning Line

该设备主要用于在产线中对板材进行输送和精确定位，以便于后续机器人或桁架机械手准确抓取。输送传输定位台（辊式定位台）是一个高度标准化、高精度、高可靠性的板材预处理工作站将随意放置的板材迅速且精确地固定在一个已知的、可重复的位置上，为后续的机器人抓取、折弯等工序提供了至关重要的位置基准，是实现产线工序间自动化、无人化衔接的核心辅助设备之一。

This equipment is mainly used to convey and precisely position sheet materials within the production line, ensuring accurate pickup by subsequent robots or gantry manipulators. The conveyor positioning table (roller-type positioning station) is a highly standardized, high-precision, and highly reliable sheet pre-processing workstation. It quickly and accurately fixes randomly placed sheets into a known and repeatable reference position, providing a critical positioning benchmark for robotic handling, bending, and other downstream processes. It is one of the key auxiliary devices enabling automated and unmanned process integration between production stages.

## 6、折边机上下料设备 Edge Bending Machine Loading &amp; Unloading System

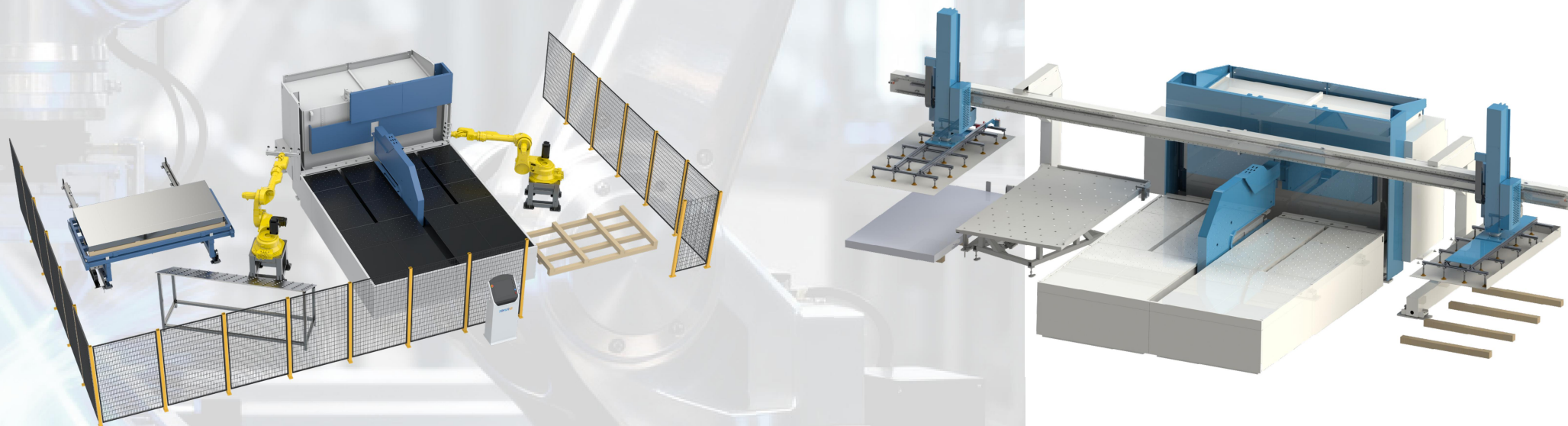

## 折弯中心上下料 Edge Bending Machine Loading &amp; Unloading System

由折弯中心与工业机器人 / 行架机械手及全套周边辅助设备组成的自动化单元，旨在替代人工，实现从取料、定位、送料到下料码垛的全流程自动化。

This automation unit consists of an industrial robot or gantry manipulator, along with a complete set of peripheral auxiliary equipment. It is designed to replace manual operations and achieve full-process automation—from material picking, positioning, and feeding to unloading and palletizing.

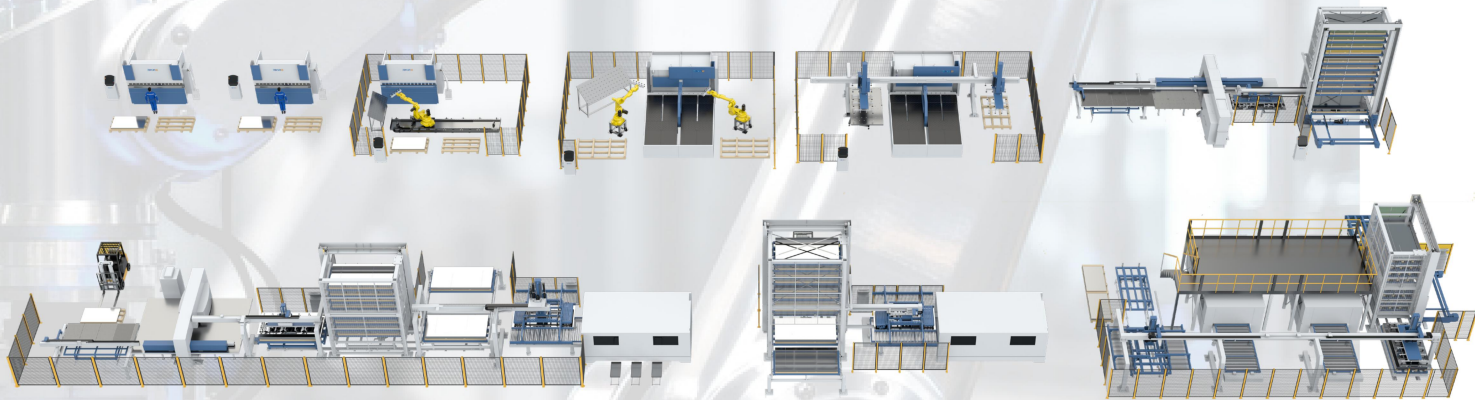
**设备组成:****System Composition:**

## 1 激光自动化生产单元 1 GL3015-02

Laser Automation Production Unit 1 – GL3015-02

## 2 激光自动化生产单元 2 GL3015-01

Laser Automation Production Unit 2 – GL3015-01

## 3 单库拖数冲自动化 + 激光自动化 GLP3015

Single-Storage Punch Automation + Laser Automation – GLP3015

## 4 数冲自动化生产单元 GP3015

CNC Punch Automation Production GP3015

## 5 折弯单元自动化 EB-2412

Bending Unit Automation EB-2412

## 6 折弯机械手自动化 EB-ER130

Press Brake Robot Automation EB-ER130

## 7 AGV 自动化搬运

AGV Automated Material Handling System

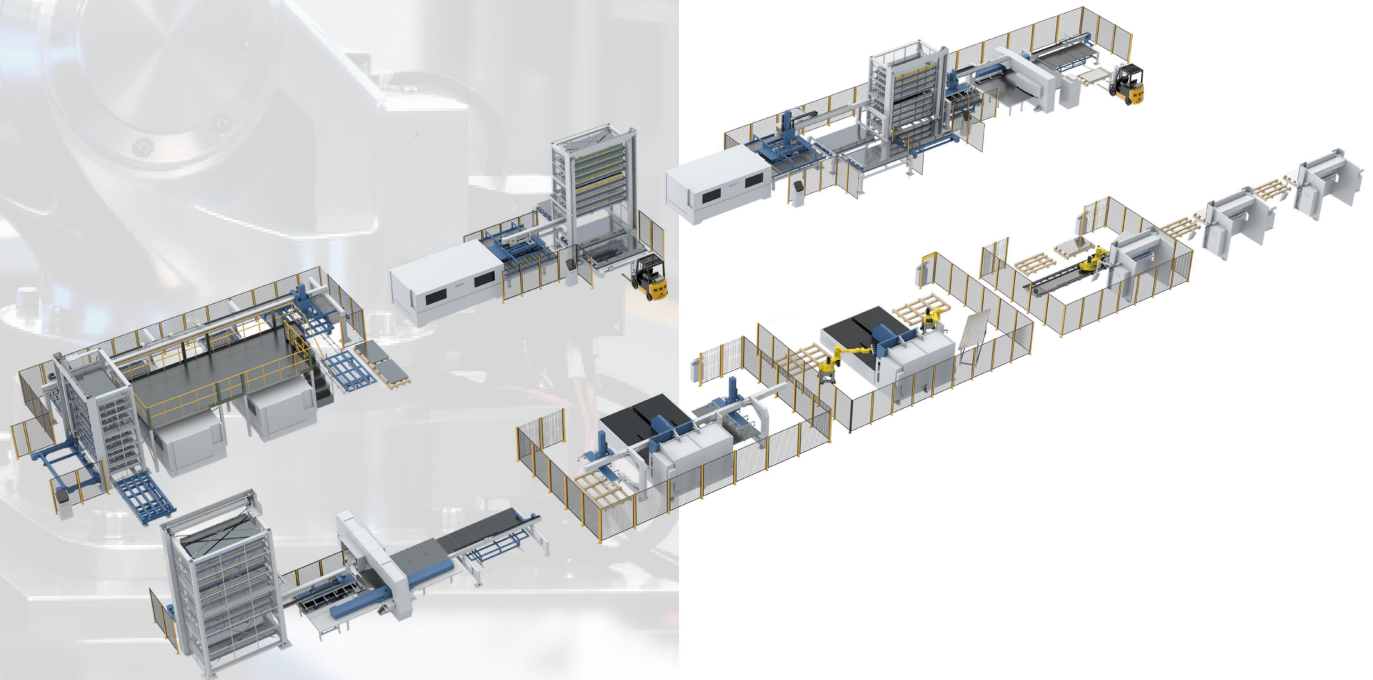

## 1、激光自动化生产单元 1 GL3015-02

Laser Automation Production Unit 1 – GL3015-02

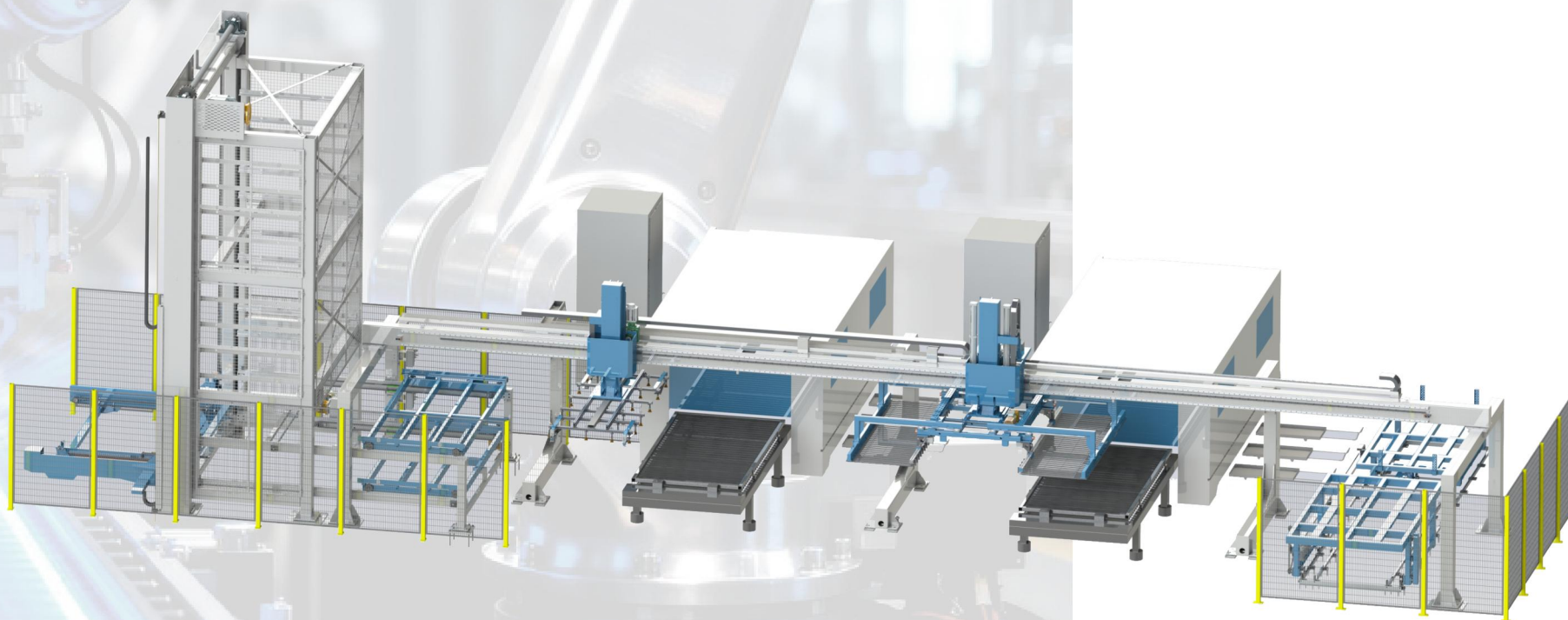

激光自动化生产单元 1 GL3015-02 Laser Automation Production Unit 1 – GL3015-02

激光自动化生产单元 1 GL3015-02 是专为激光切割机设计的高效率、高柔性全自动上下料解决方案。其“一拖二”的设计理念、吸盘上料 / 插齿下料的工艺组合、双层台车的物流配置以及与上层信息系统的深度集成，共同构成了其核心竞争力。该单元是实现钣金工厂“黑灯车间”、构建钣金智能工厂前端激光切割环节无人化、自动化的关键标准模块。

The GL3015-02 is a high-efficiency and highly flexible fully automatic loading and unloading solution specifically designed for laser cutting machines. Its “one-to-two” configuration, combined with vacuum suction loading and fork-type unloading technology, dual-layer transfer cart logistics setup, and deep integration with upper-level information systems, forms its core competitive advantages. This unit serves as a key standard module for achieving “lights-out” laser workshops and realizing unmanned and automated front-end laser cutting processes in smart sheet metal factories.

## 2、激光自动化生产单元 2 GL3015-01

Laser Automation Production Unit 2 – GL3015-01

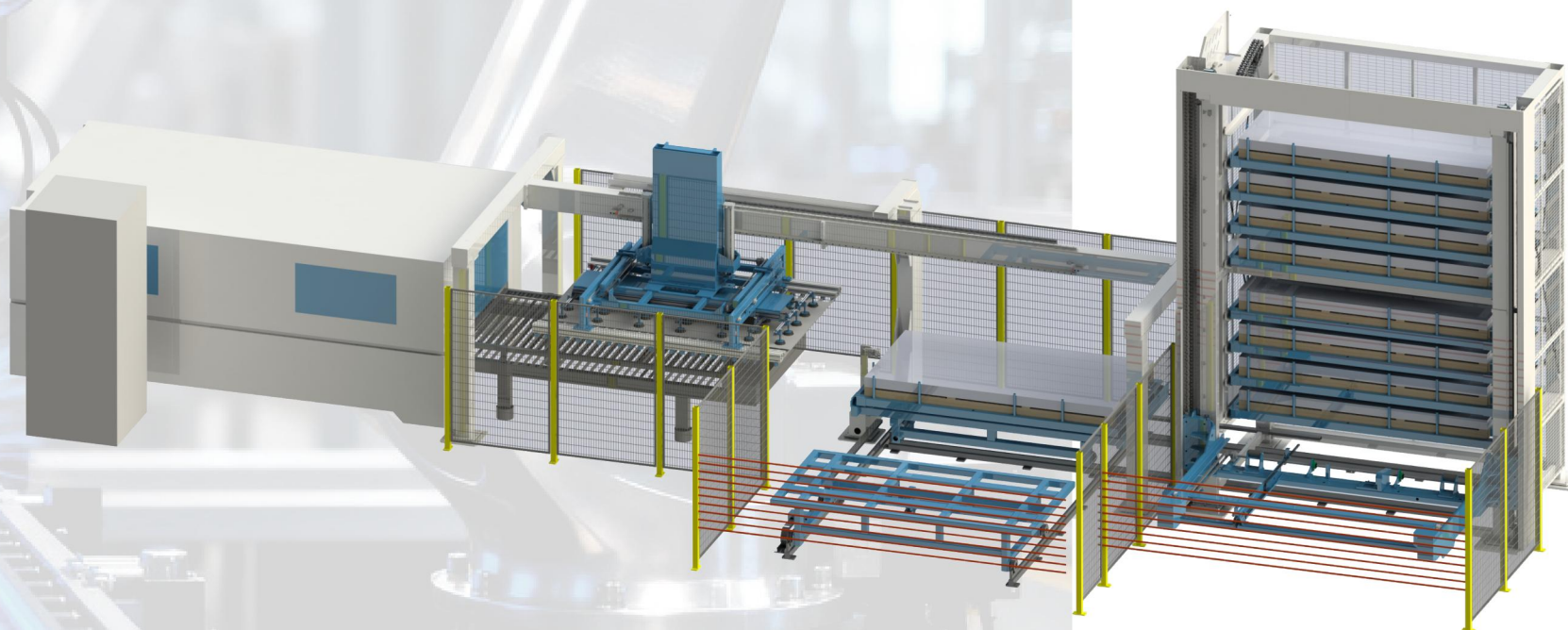

## 激光自动化生产单元 2 GL3015-01 Laser Automation Production Unit 2 – GL3015-01

激光自动化生产单元 2 GL3015-01 是为单台激光切割机设计的高效率、全自动化上下料解决方案。其核心价值在于实现了激光切割前置物料流的无人化与信息化闭环，是构建钣金智能工厂前端环节的关键标准配置。相比一拖二方案（GL3015-02），该方案成本投入更聚焦，是实现单台激光设备自动化升级的典型选择。其核心组件（料库、上下料机械手）的技术规格与前述 GL3015-02 相似，仅在服务主机数量和物流台车配置上有所不同，以适应特定生产规模和布局需求。

The GL3015-01 is a high-efficiency, fully automated loading and unloading solution designed for a single laser cutting machine. Its core value lies in enabling unmanned and digital closed-loop control of the pre-laser material flow, making it a fundamental configuration for the front-end of a smart sheet metal factory.

Compared with the one-to-two solution (GL3015-02), this model offers a more focused cost investment and is ideal for upgrading a single laser machine to automation. Its core components (storage system and loading/unloading manipulator) share similar technical specifications with the GL3015-02, differing mainly in the number of serviced machines and logistics cart configuration to meet specific production scale and layout requirements.

## 3、单库拖数冲自动化 + 激光自动化 GLP3015

Single-Storage Punch Automation + Laser Automation – GLP3015

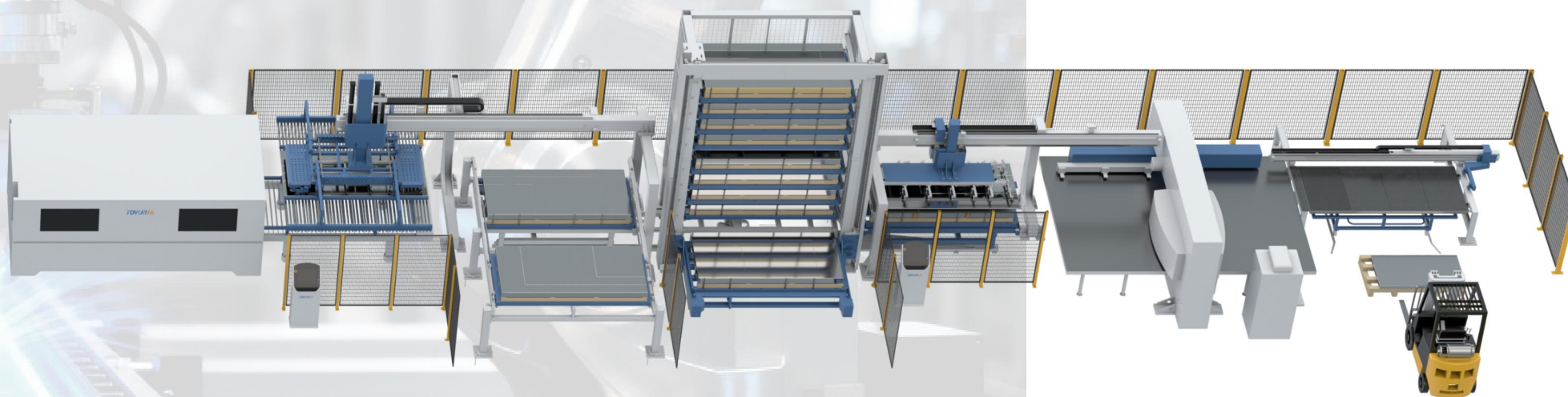

## 单库拖数冲自动化 + 激光自动化 GLP3015 Single-Storage Punch Automation + Laser Automation GLP3015

以单塔智能料库为核心枢纽，通过成熟的 GL3015 系列激光自动单元和 GP3015 系列数冲自动单元，结合自主研发的 WIS 产线控制系统，为客户构建了一个高效率、高柔性、少人化的钣金加工生产单元。该方案是实现冲、切工序自动化升级，迈向智能制造的理想选择。具体选型时，需根据板材主流尺寸（2512/3015/4020）、激光机与冲床的数量、以及车间具体布局来确定最终配置。

Centered around a single-tower intelligent storage system as the core hub, and combined with the proven GL3015 series laser automation unit and GP3015 series CNC punching automation unit, together with the self-developed WIS production line control system, this solution delivers a high-efficiency, high-flexibility, and reduced-labor sheet metal manufacturing unit.

It represents an ideal choice for upgrading punching and cutting processes toward automation and advancing into intelligent manufacturing.

#### 4、数冲自动化生产单元 GP3015

CNC Punch Automation Production – GP3015

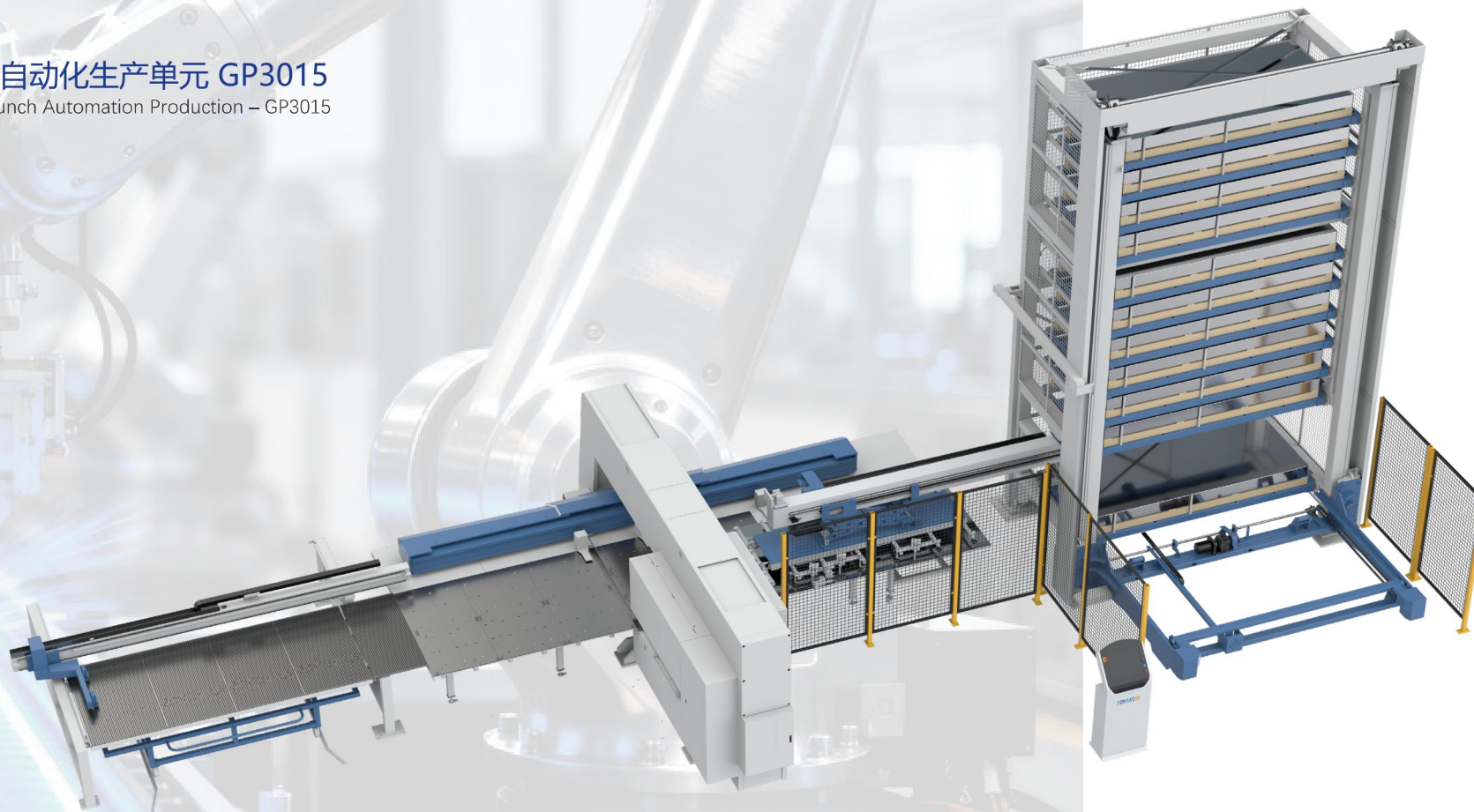

数冲自动化生产单元 GP3015 CNC Punch Automation Production – GP3015

通过整合原材料料库、自动分张取料、高精度上料、自动收料码垛等功能，实现了从原材料到半成品 / 成品的连续自动化加工，完美替代人工完成上、下料操作，是构建钣金智能工厂的核心单元。

By integrating raw material storage, automatic sheet separation, high-precision loading, and automatic unloading and palletizing, this unit enables continuous automated processing from raw materials to semi-finished or finished products. It fully replaces manual loading and unloading operations and serves as a core module in building a smart sheet metal factory.

## 5、折弯单元自动化 EB-2412 Bending Unit Automation EB-2412

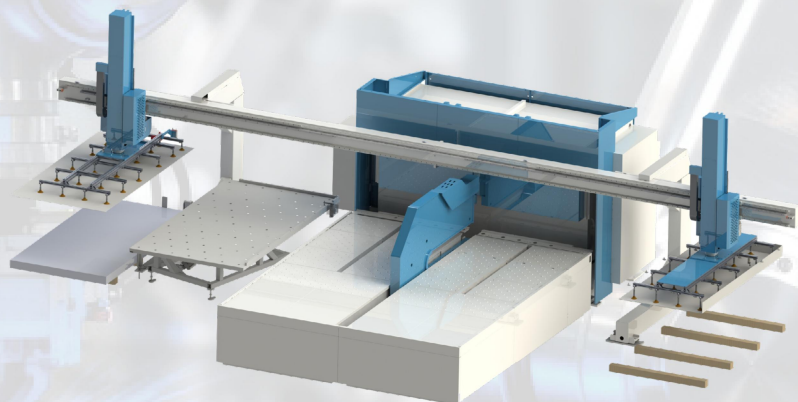

## 折弯中心上下料 Panel Bender Loading &amp; Unloading Automation

由折弯中心与工业机器人 / 行架机械手及全套周边辅助设备组成的自动化单元，旨在替代人工，实现从取料、定位、送料到下料码垛的全流程自动化。

This automation unit consists of an industrial robot or gantry manipulator, along with a complete set of peripheral auxiliary equipment. It is designed to replace manual operations and achieve full-process automation—from material picking, positioning, and feeding to unloading and palletizing.

## 6、折弯机械手自动化 EB-ER130 Press Brake Robot Automation EB-ER130

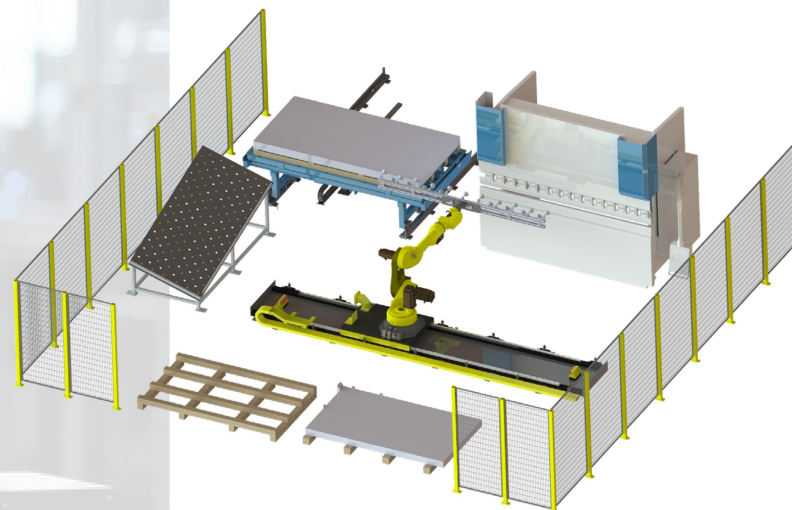

## 折弯机械手自动化 Press Brake Robot Automation

是实现钣金加工无人化、智能化的核心执行单元。其选型关键在于根据工件最大尺寸、重量、工艺复杂度确定机器人负载与臂展，并根据生产模式（单机、连线、对接料库）确定是否需配置第七轴及其长度，同时必须确保与折弯机的控制系统深度兼容，以实现精准的联动跟随。

This is the core execution unit for achieving unmanned and intelligent sheet metal bending. The key to system configuration lies in determining the robot payload and arm reach based on the maximum workpiece size, weight, and process complexity. Depending on the production mode (standalone, inline, or connected to storage), a seventh axis and its length may be required. Deep compatibility with the press brake control system is essential to ensure precise synchronized motion and coordinated operation.

## 7、AGV 自动化搬运 AGV Automated Material Handling

AGV 自动化搬运系统是连接“信息流”与“实物流”的智能化纽带，实现了物理上的无人搬运，数据驱动的任务执行，7x24 小时连续作业。

The AGV automated handling system acts as the intelligent link between information flow and material flow. It enables physically unmanned transportation, data-driven task execution, and continuous 7x24-hour operation.

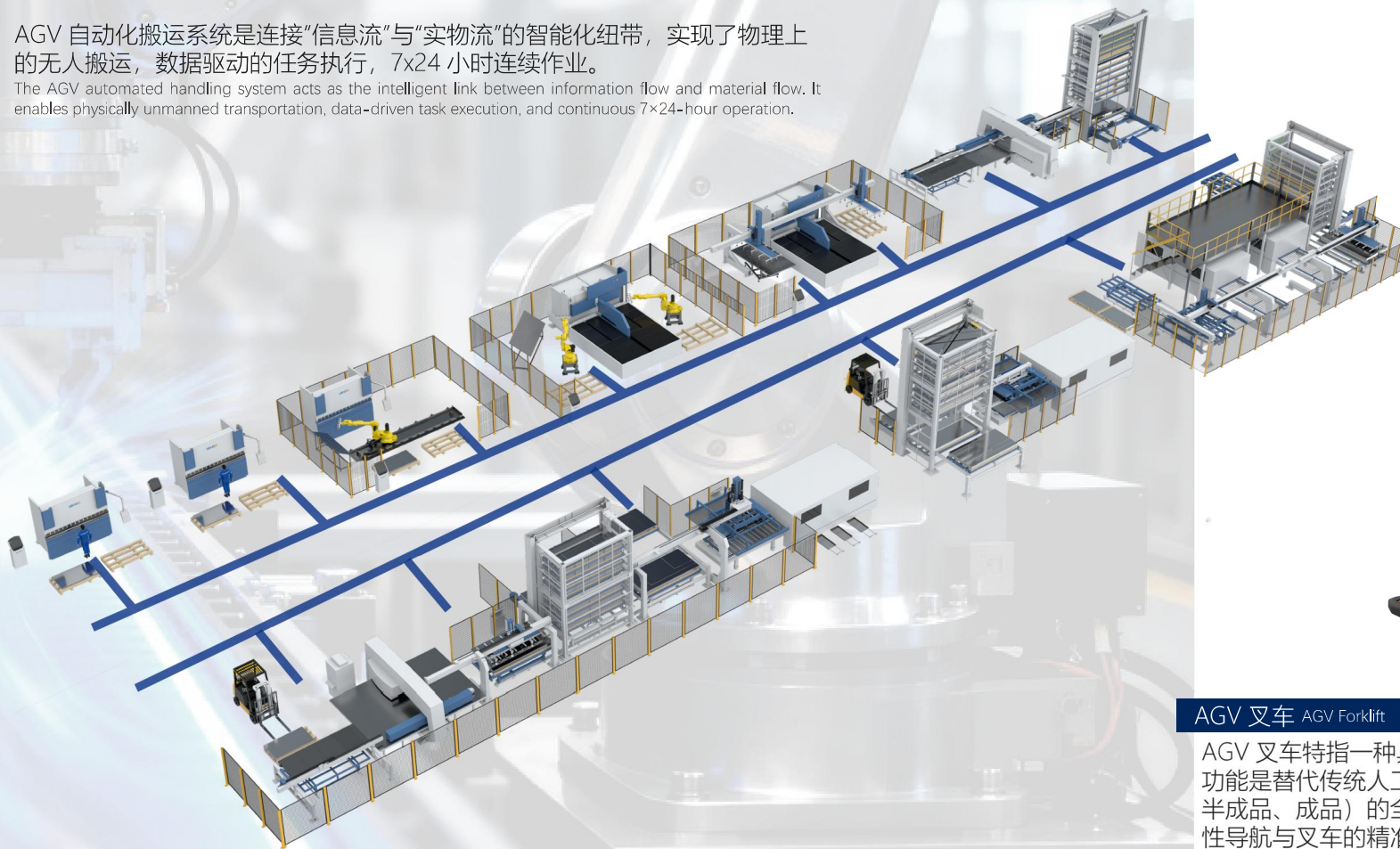

AGV 叉车 AGV Forklift

AGV 叉车特指一种具备叉车取放功能的自动导引运输车。其主要功能是替代传统人工叉车，在智能工厂内部实现物料（原材料、半成品、成品）的全自动化搬运、对接和配送。它将 AGV 的柔性导航与叉车的精准举升、移载能力相结合，是实现车间级物流无人化的关键设备。

An AGV forklift refers to an automated guided vehicle equipped with forklift lifting and handling functions. It replaces traditional manual forklifts within smart factories, enabling fully automated transportation, docking, and distribution of raw materials, semi-finished, and finished products. By combining flexible AGV navigation with precise lifting and transfer capabilities, it serves as a key solution for achieving unmanned workshop-level logistics.

# 04 焊接自动化

Welding automation

## 1、焊接自动化 Welding automation

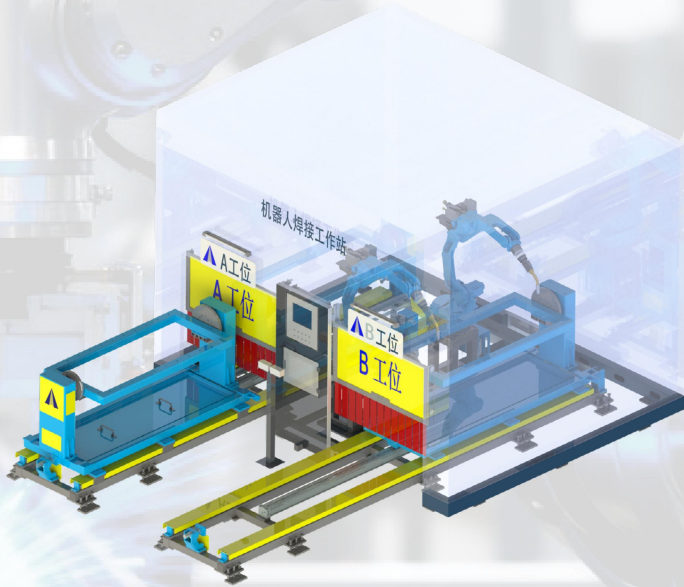

### 焊接自动化 Welding automation

焊接自动化通过机器人替代人工，实现 24 小时高效连续作业，生产效率提升 50% 以上。它确保焊接质量高度一致，消除人为波动，废品率极低。同时大幅降低对熟练焊工的依赖和人力成本，并通过人机隔离与烟尘净化，保障安全、改善环境。系统柔性高，支持快速换型，并能无缝集成到智能产线中，是企业提升竞争力、实现智能制造的关键升级。

Welding automation replaces manual labor with robotic systems, enabling 24-hour continuous and efficient operation and increasing productivity by more than 50%. It ensures highly consistent welding quality, eliminates human variability, and maintains an extremely low defect rate. At the same time, it significantly reduces dependence on skilled welders and lowers labor costs. Through human-machine isolation and fume extraction systems, it enhances workplace safety and improves the working environment. With high flexibility, the system supports fast model changeovers and can be seamlessly integrated into intelligent production lines, making it a key upgrade for enterprises to enhance competitiveness and achieve smart manufacturing.

# 05 物流仓储自动化

Warehouse and logistics automation



## 1、物流仓储自动化 Warehouse and logistics automation

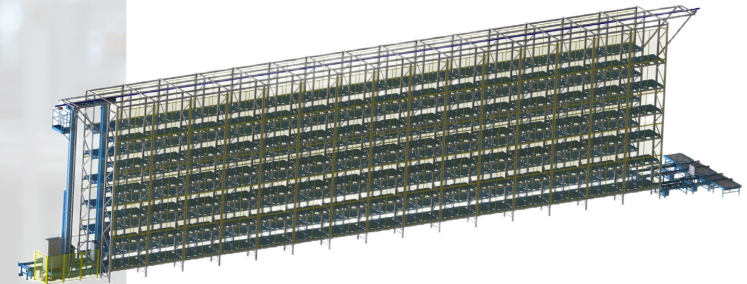

### 物流仓储自动化 Warehouse and logistics automation

物流仓储自动化通过立体料库、堆垛机与 TY-WIS 系统，实现物料高密度存储与智能调度。空间利用率提升 300% 以上，存取效率提高 50%-80%，搭配 AGV 叉车实现 24 小时无人化“黑灯”作业。系统精准管理库存，实现先进先出与全程追溯，大幅降低人力依赖与差错率，是构建高效物流运输、提升供应链响应速度的核心基石。

Through the integration of an automated vertical storage system, stacker cranes, and the TY-WIS control system, the automated logistics and warehousing solution enables high-density material storage and intelligent scheduling. Space utilization is increased by more than 300%, while storage and retrieval efficiency improves by 50%-80%. When combined with AGV forklifts, the system supports 24/7 unmanned "lights-out" operation. With precise inventory control, the system ensures first-in, first-out (FIFO) management and full-process traceability, significantly reducing labor dependency and error rates. It serves as a fundamental cornerstone for building highly efficient material flow systems and enhancing overall supply chain responsiveness.

# 06 应用案例

Application examples.

## 电梯行业

Elevator industry

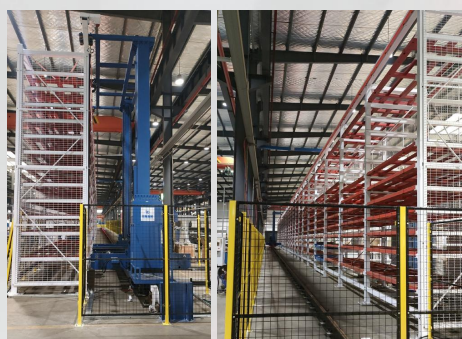
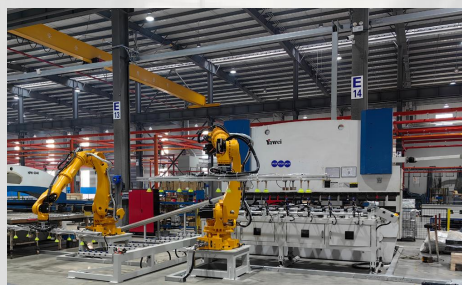

# 06 应用案例

Application examples.

## 电梯行业

Elevator industry

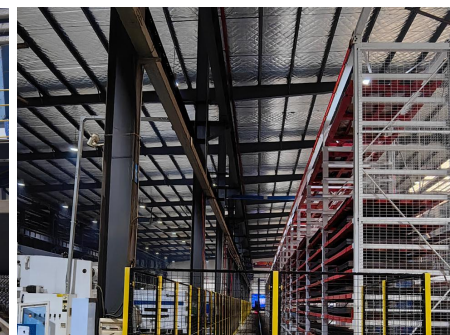
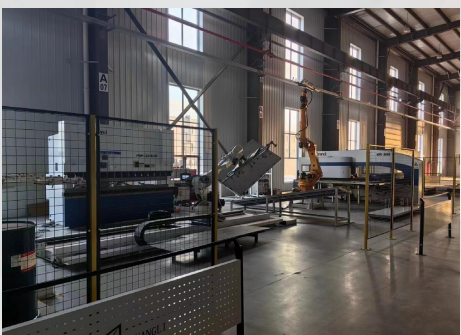
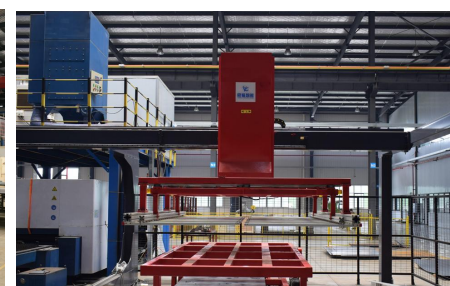
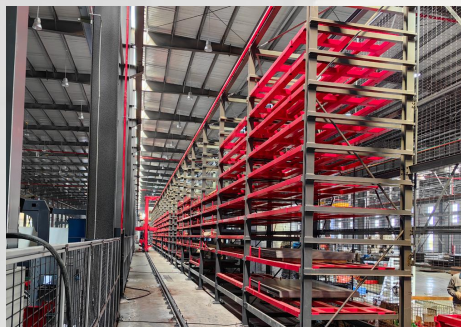

# 06 应用案例

Application examples.

## 电力、通讯及新能源行业

Power, telecommunications and new energy industries



# 06 应用案例

Application examples.

## 电力、通讯及新能源行业

Power, telecommunications and new energy industries



# 06 应用案例

Application examples.

## 集装箱行业

Container industry



## 医疗器械行业

Medical device industry



# 06 应用案例

Application examples.

## 焊接自动化

Welding automation



## 折弯自动化

Bending automation.

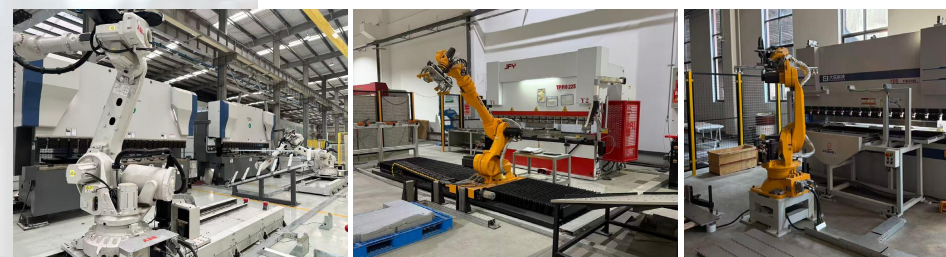

## 物流仓储行业

Logistics and warehousing industry

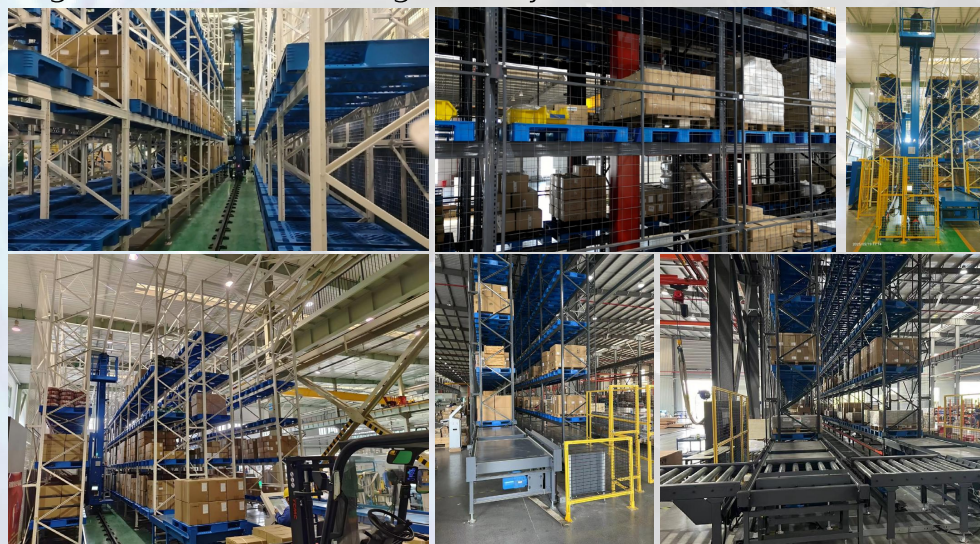

06

应用案例

Application examples.

MES  
MES

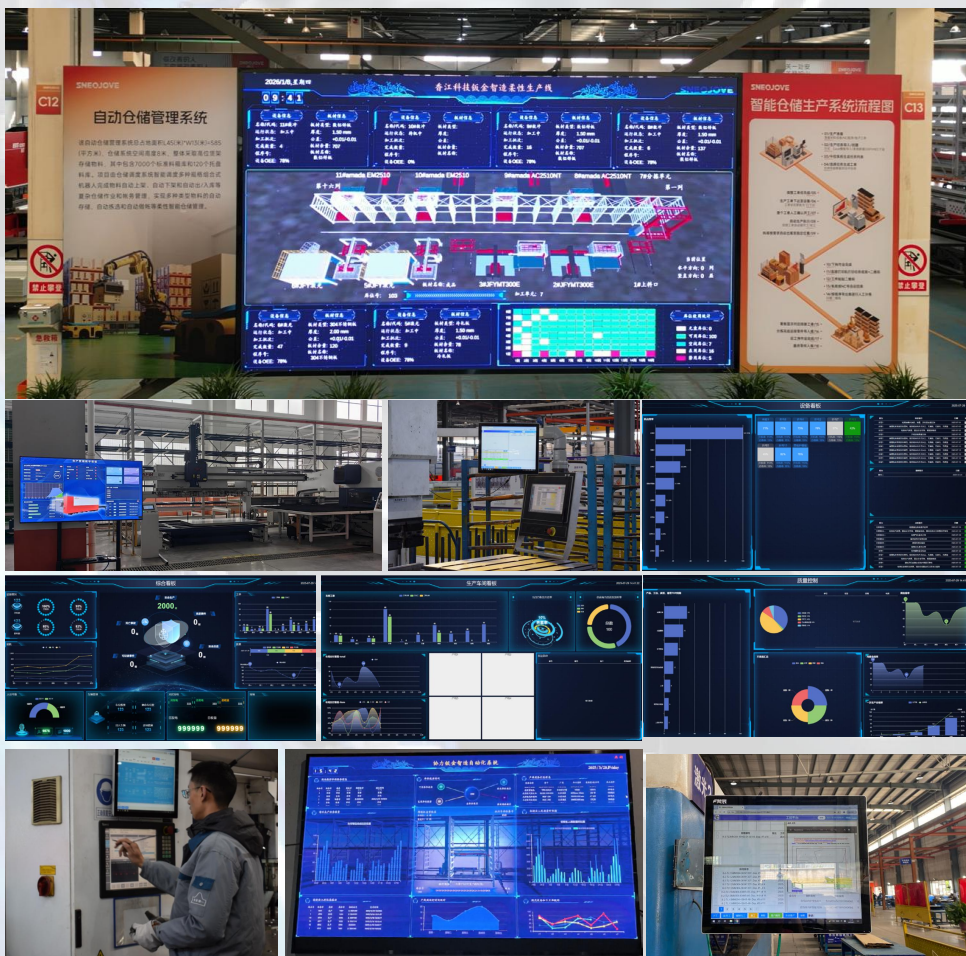

其他行业  
Other industry

